

# DIRECT DRIVEN FIRE WATER PUMP WITH ANGLE GEAR



Keep going. Keep safe.

**EUREKA**

# ENSURE SAFETY THROUGH PROVEN **EXPERIENCE**

Fire protection for all offshore applications.



STATFJORD A, STATOIL



CLAIR, BP



ÅSGARD A, STATOIL



SNORRE B, STATOIL



FPSO FARWAH, TOTAL



KRISTIN, STATOIL



TROLL C, SHELL



OSEBERG SØR, STATOIL



AGBAMI FPSO, CHEVRON



SKARV, BP



GRANE, STATOIL



GUDRUN, STATOIL

OVER 150 FIRE WATER PUMP SYSTEMS  
delivered to the offshore oil & gas industry

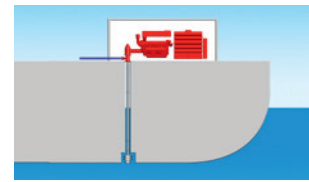

# DIRECT DRIVEN FIRE WATER PUMP WITH ANGLE GEAR

## ADVANTAGES

- High efficiency and low power demand
- Compact Design Require Less Space
- Significant Weight reduction
- Greener production due to lower weight and dimensions
- Lower CO<sup>2</sup> emission per tons due to less steel required
- Lower fuel consumption and exhaust emission
- NFPA 20 Control system
- Soft start of Fire Water Pump
- Cool down stop sequence of diesel engine
- Easy access for Maintenance, components located above sea level
- 10 year warranty of submerged components
- Low price

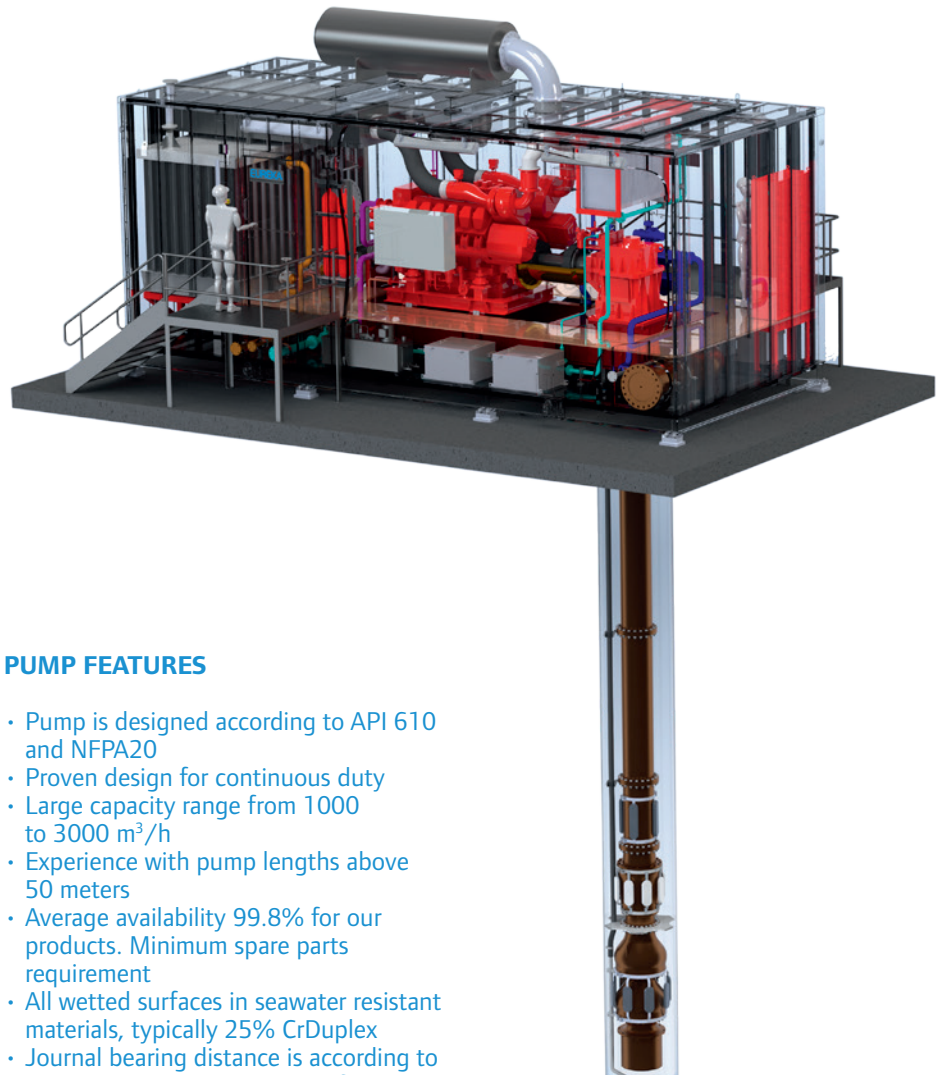

## SYSTEM FEATURES

- Space, weight and cost effective due to few main components
- Simple installation and easy alignment
- Robust, complete and fully mechanical NFPA 20 designed system
- The system is suitable for Hazardous Area zone 2
- High efficiency

## PUMP FEATURES

- Pump is designed according to API 610 and NFPA20
- Proven design for continuous duty
- Large capacity range from 1000 to 3000 m<sup>3</sup>/h
- Experience with pump lengths above 50 meters
- Average availability 99.8% for our products. Minimum spare parts requirement
- All wetted surfaces in seawater resistant materials, typically 25% CrDuplex
- Journal bearing distance is according to API 610. The running speed of the pump is max. 75% of the critical speed, resulting in low vibration level
- Journal bearings have excellent dry running capabilities during start up
- The labyrinth seal is a non-contact design with the same life time as the pump
- Option: Submerged non-slam no-return valve to prevent water hammering during start up and stop.
- The cooling water is taken from pump discharge and the complete system is independent of external cooling water

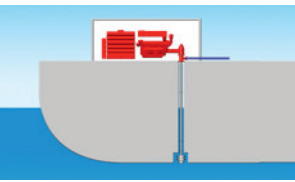

# DIRECT DRIVEN FIRE WATER PUMP WITH ANGLE GEAR

## EUREKA STANDARD PRODUCTS

Flow (m <sup>3</sup> /h)	Pump Size	NPSHr 150% (m)	Pump OD (mm)	Caisson ID (mm)	Pump Power Consumption (kW)	Pump Speed (rpm)	Diesel Engine Power Consump. (kW)	Diesel Engine Speed (rpm)	Weight (kg)	Enclosure Dimensions (mm)		
										Lenght A	Width B	Height C
1000	CD250-2	12	730	880	700	1760	760	1800	37100	7000	4000	4000
1500	CD400-2	15	693	850	1000	1760	1100	1800	47000	8000	4000	4000
2000	CD3-400-2	22	693	850	1200	1760	1270	1800	47000	8000	4000	4000
2000	CD450L2-3	12	776	930	1100	1180	1165	1800	48500	8000	4000	4000
2500	CD450L2-2	20	776	930	1400	1480	1470	1800	49400	8000	4000	4000
3000	CD450V2-2	15	964	1120	1850	1180	1960	1800	58700	9000	4000	4000

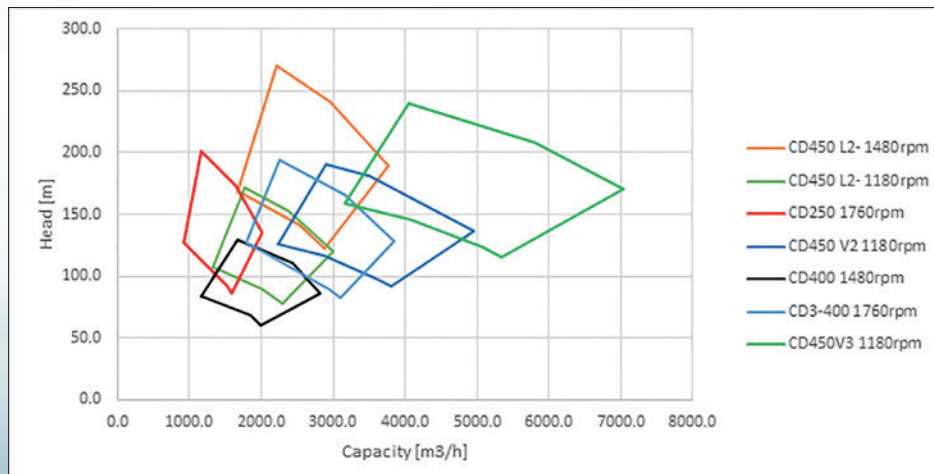

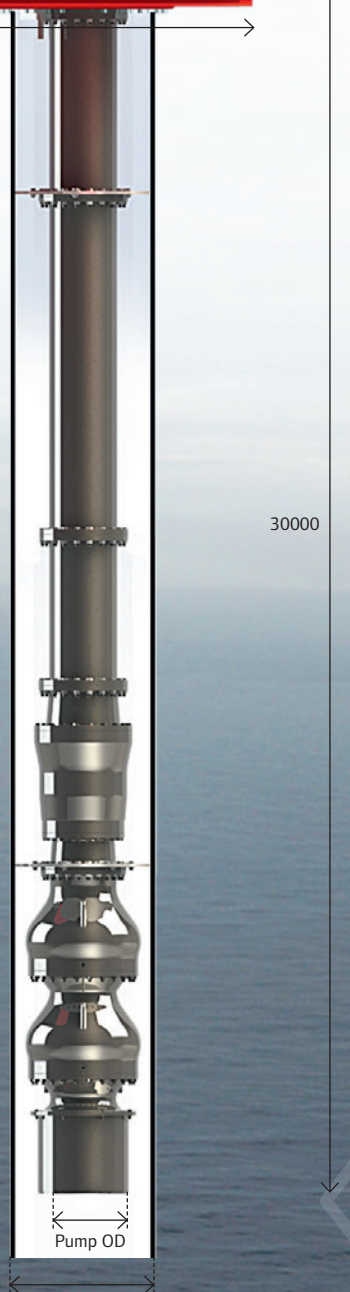
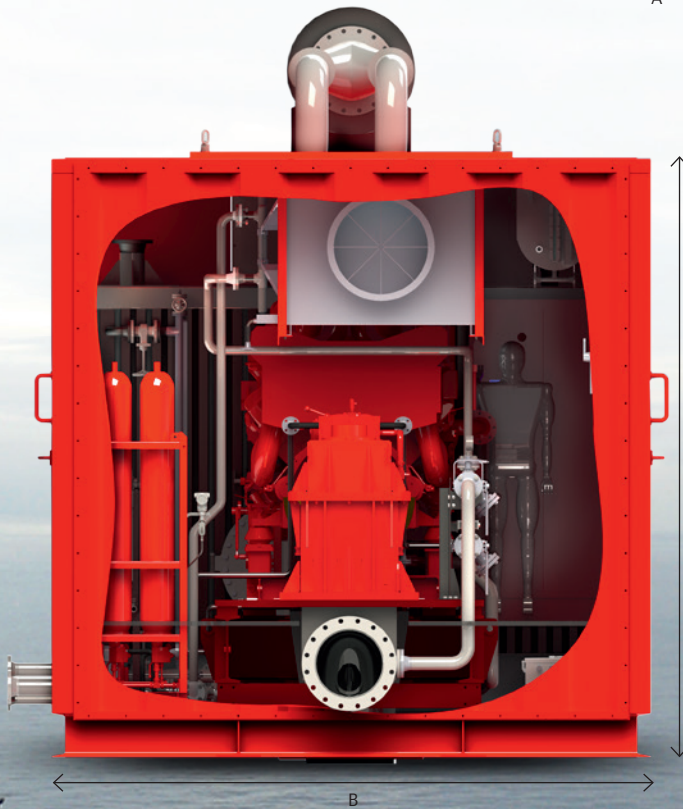
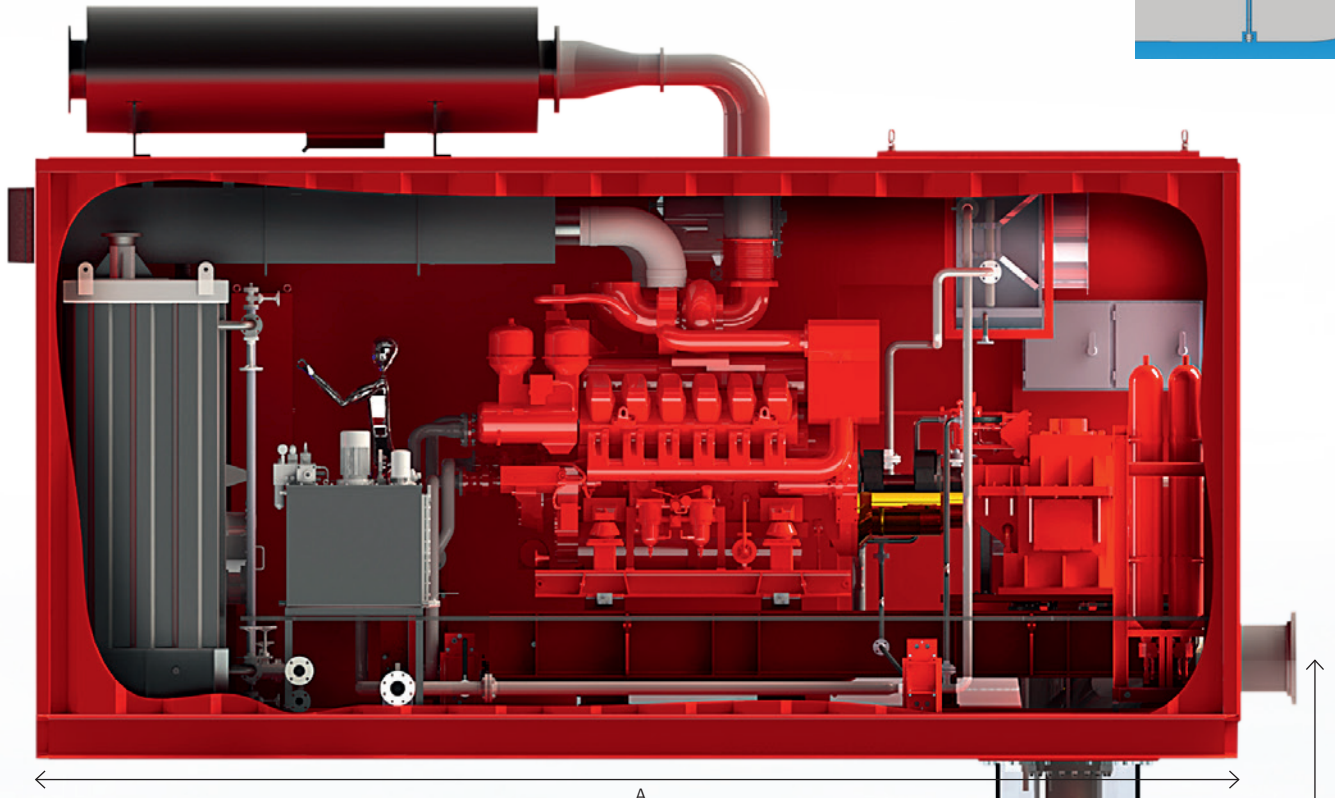
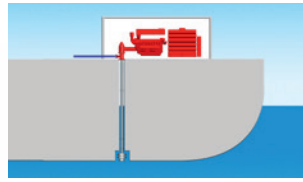

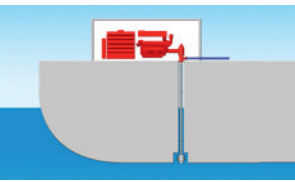

# DIRECT DRIVEN FIRE WATER PUMP WITH ANGLE GEAR

## THE DIFFERENCE

The differences between Diesel Electric driven Fire Water Pump with Electric Submerged Pump and Direct Diesel driven Line-Shaft Fire Water Pump with Angle Gear:

### Typical Fire Water Pump package:

Rated Capacity: 2500 m<sup>3</sup>/h  
Rated Head: 160 m  
Pump Power rating: 1500 kW

### Direct driven Fire Water Pump with Angle Gear

Engine rating: 1680 kW  
Efficiency total: 97%  
Weight: 55000 kg  
Dimension: L x W x H = 8.0 x 4.0 x 4.0 meter

### Diesel Electric Fire Water Pump Gen. set

Engine rating: 2240 kW  
Efficiency total: 86%  
Weight: 75000 kg  
Dimension: L x W x H = 11.0 x 4.0 x 4.0 meter



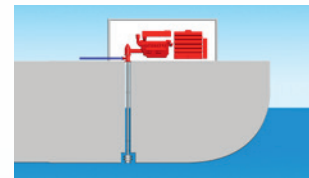

# ASSEMBLY & TESTING FACILITIES

## SØRUMSAND

Sørumsand is the main assembly & test facility for CAPEX projects located in between Oslo and the airport. It consist of 8000 m<sup>2</sup> workshop & assembly area, 1000 m<sup>2</sup> warehouse and 1000 m<sup>2</sup> test bed. The work shop is equipped with balancing machine, lathe and cranes with SWL up to 150 tonnes. The test bed is a state of the art indoor test station in compliance to ISO 9906. It is equipped with load bank, frequency converter, transformers, switchgears and other high and low voltage equipment for testing in compliance with worldwide customer requirements. It also contains test basins with test loop and connection to a 60 m deep hole with 1.8 m dia for testing of deep well pump in full length.

The test station is purpose build for testing of Eureka scope of pumps and generator sets with capacities up to 10 000 m<sup>3</sup>/h and powers up to 3.5 MW with all applicable voltages:

- Full scale testing of firewater pump packages comprising of diesel gensets connected to full length electric submersible pumps.
- Testing of sea water lift pumps in full length. Line shaft pumps and electric submersible pumps.
- Testing of essential and emergency generators.
- Testing of all types of dry mounted pumps.

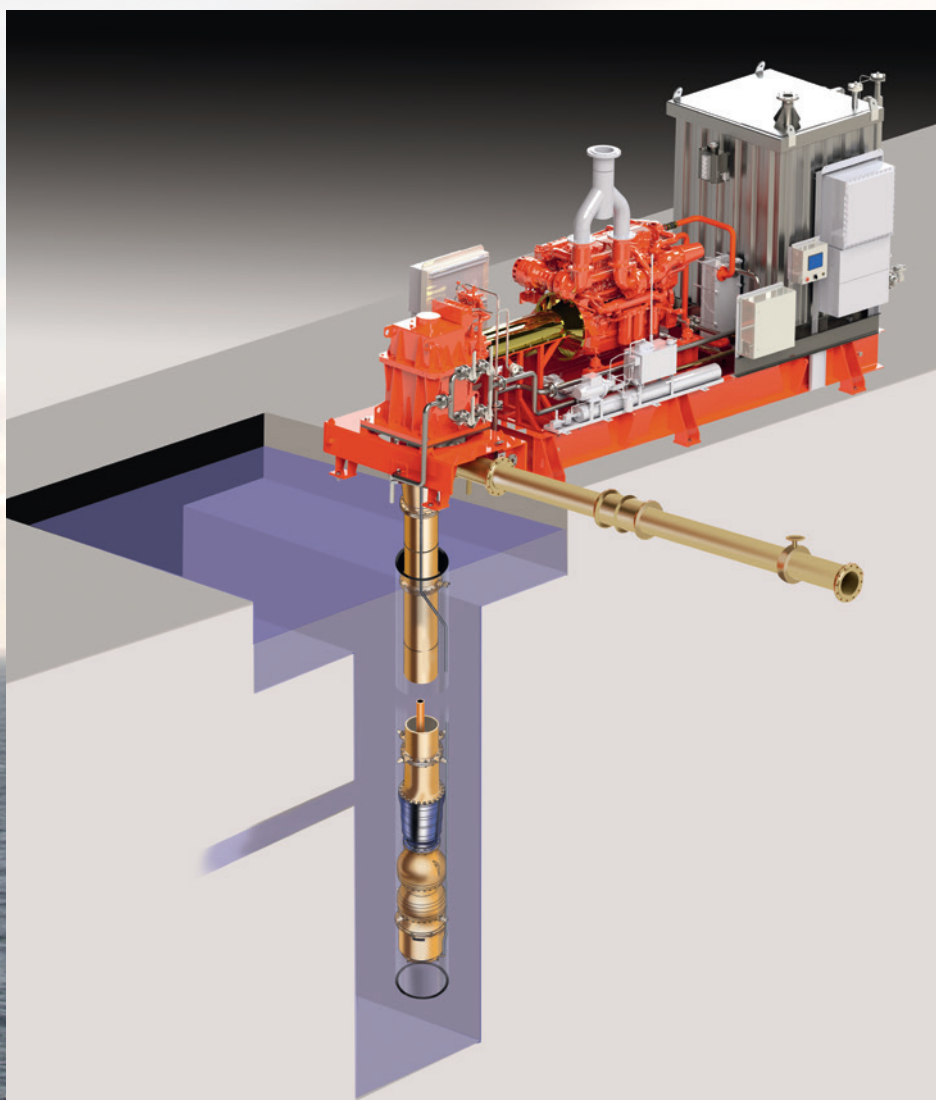

EUREKA PUMPS AS is a Norwegian pump supplier with more than 35 years of experience in the oil & gas and marine industry, offering a range of pumps and generator sets that covers a majority of applications. EUREKA PUMPS supplies to new builds and operates advanced maintenance and service. The company also offers services for upgrading, modification, equipment testing, installation and commissioning.

EUREKA PUMPS is a market leader among companies operating on the Norwegian Continental shelf, and it is also present in International markets with selected applications, based on own technology. EUREKA PUMPS main office is in Oslo (Lysaker), Norway, and has branch offices at strategic locations along the Norwegian coast. EUREKA PUMPS also has offices in Houston St. Johns, Busan and Kuala Lumpur.

EUREKA PUMPS is one of five companies in the ALIGN group, a leading supplier of production equipment and safety critical products and solutions. ALIGN offers services ensuring continuous production, a perspective that safeguards optimal operations and lower life-cycle costs. ALIGN is a result of the demerger of Bjørge AS, which was carried out in December 2010. The ALIGN group is owned by Convento Capital and HitecVision.

■ EUREKA PUMPS AS

■ Agent



Tel. + 47 815 31 002

[www.eureka.no](http://www.eureka.no)

EUREKA PUMPS AS | P.O. Box 229, NO-1326 Lysaker, Norway | Oksenøyveien 10, NO-1366 Lysaker, Norway

# EUREKA